



Weights and Dimensions

External Dimensions:

Length: 5565mm
Width: 2010mm
Height: 3030mm

Approx. Weight:

Unladen Weight: 1095kg* 1095kg* 1095kg*
Axle 1: 1000kg 1250kg 1500kg
Axle 2: 1500kg 1500kg 1500kg
Gross Weight: 2000kg 2500kg 3000kg

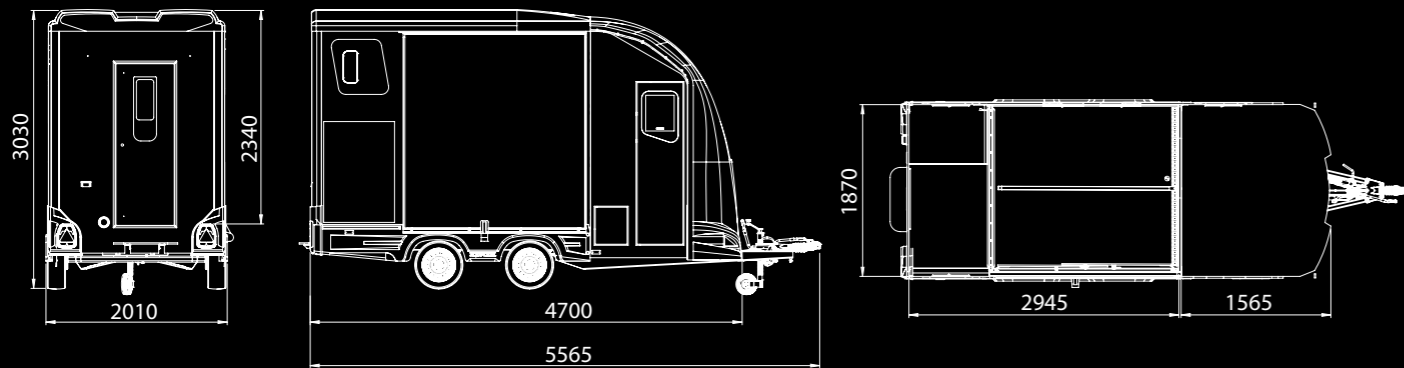

Please note some images may show optional extras not included as part of the base specification.
*Plan view shows internal dimensions



Day-Treka



Equi-Trek Day-Treka

The Day-Treka is a rear facing, spacious two horse trailer with a large tack area which is totally separate from the horse area.

It is fitted with two saddle and bridle racks and two coat hooks.

The wood free structure and composite panels make the Day-Treka light-weight but still strong and robust. It provides 7ft 9inch headroom with fully enclosed travel and a low, wide ramp, making this the number one choice for the discerning owner.

Standard gross weight is 2,000kg. It is also available in a 2,500kg and 3,000kg gross weight chassis upgrade to give a class leading payload.



Horse Area

- Self Contained Horse Area
- Adjustable Partition with PVC Skirt to Floor
- Composite High Impact Kick Boards
- Composite Panels
- Full Width Collapsible Breast Bar
- Groom's Door with Window
- Head Divider
- Two Horse and Haynet Tie Rings
- Light and Spacious Interior
- One Interior Light
- Slip Resistant Rubber Ramp
- Strong Aluminium Plank Floor
- White Easy Clean Safety Loading Doors
- Extra Vent Window
- Additional Skylight Roof Vent



Main Body

- Aerodynamic Fibreglass Mould
- Galvanised Steel Chassis
- Lockable Coupling
- Independent Suspension
- Four Fully Braked Wheels
- Built in ISO9001 Factory
- Two External Tie Rings
- Step for Easy Access through to Groom's Door
- Side Loading for Improved Safety
- Colour White as Standard, Other Colours Available at Extra Cost



Tack/Changing Area

- Easy Clean Cushion Flooring
- Living Area Door
- Mirror
- One Interior Light
- Two Saddle Racks and Two Bridle Racks
- Seat with Storage

